

Plotted By: Lopez, Shereen - Sheet: Meridian N6 - L1.50 - 2024 - 11:18:21am - K:\ORL\LA\49831018_Meridian_Park_N6_CAD_CONSTR\PlanSheets\SPWP\N6.L1.50 - LANDSCAPE_PLAN.dwg
 This document, together with the concepts and designs presented herein, is intended only for the specific purpose and client for which it was prepared. Release of and improper reliance on this document without written authorization and approval by Kimley-Horn and Associates, Inc. shall be without liability to Kimley-Horn and Associates, Inc.

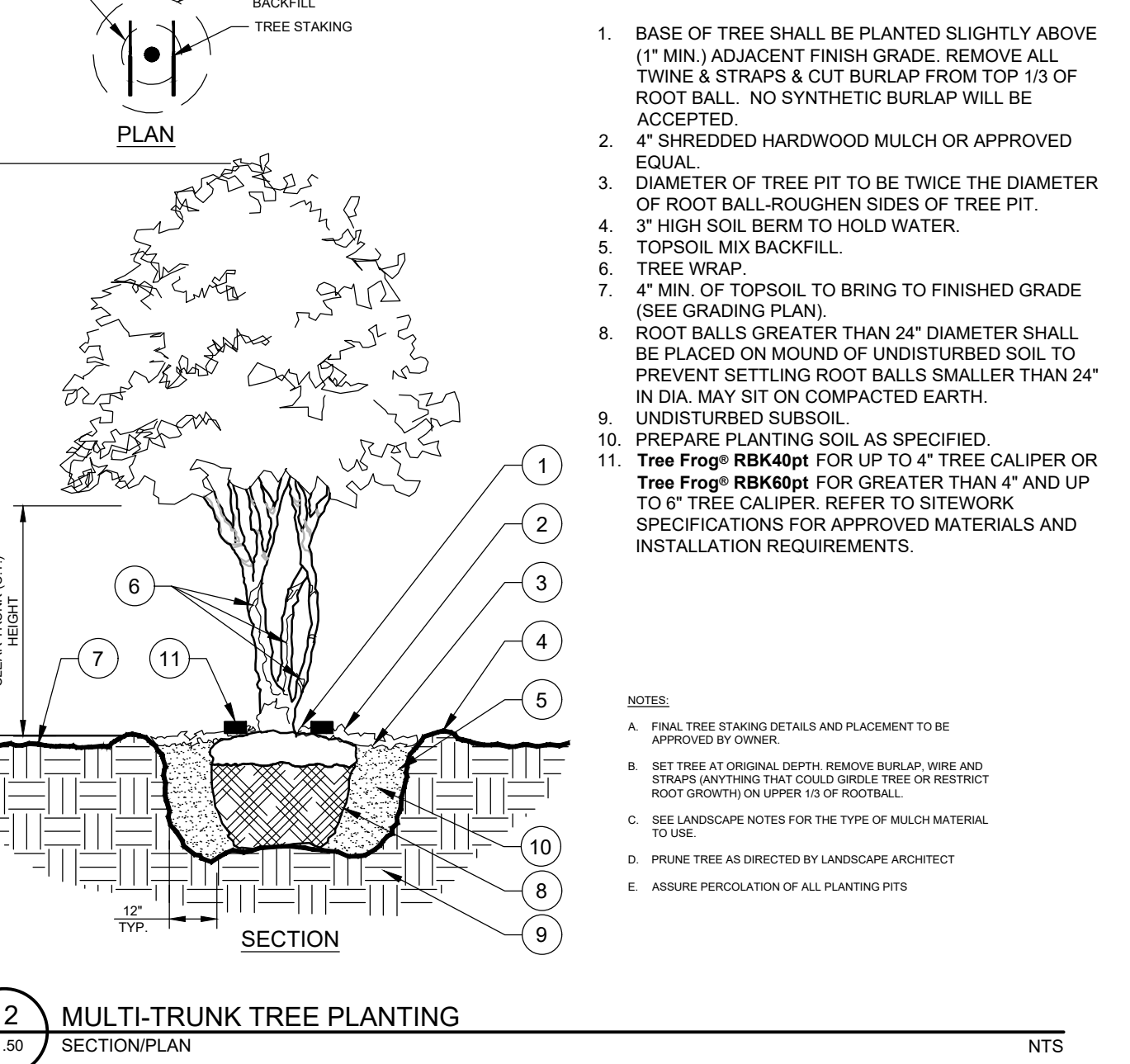
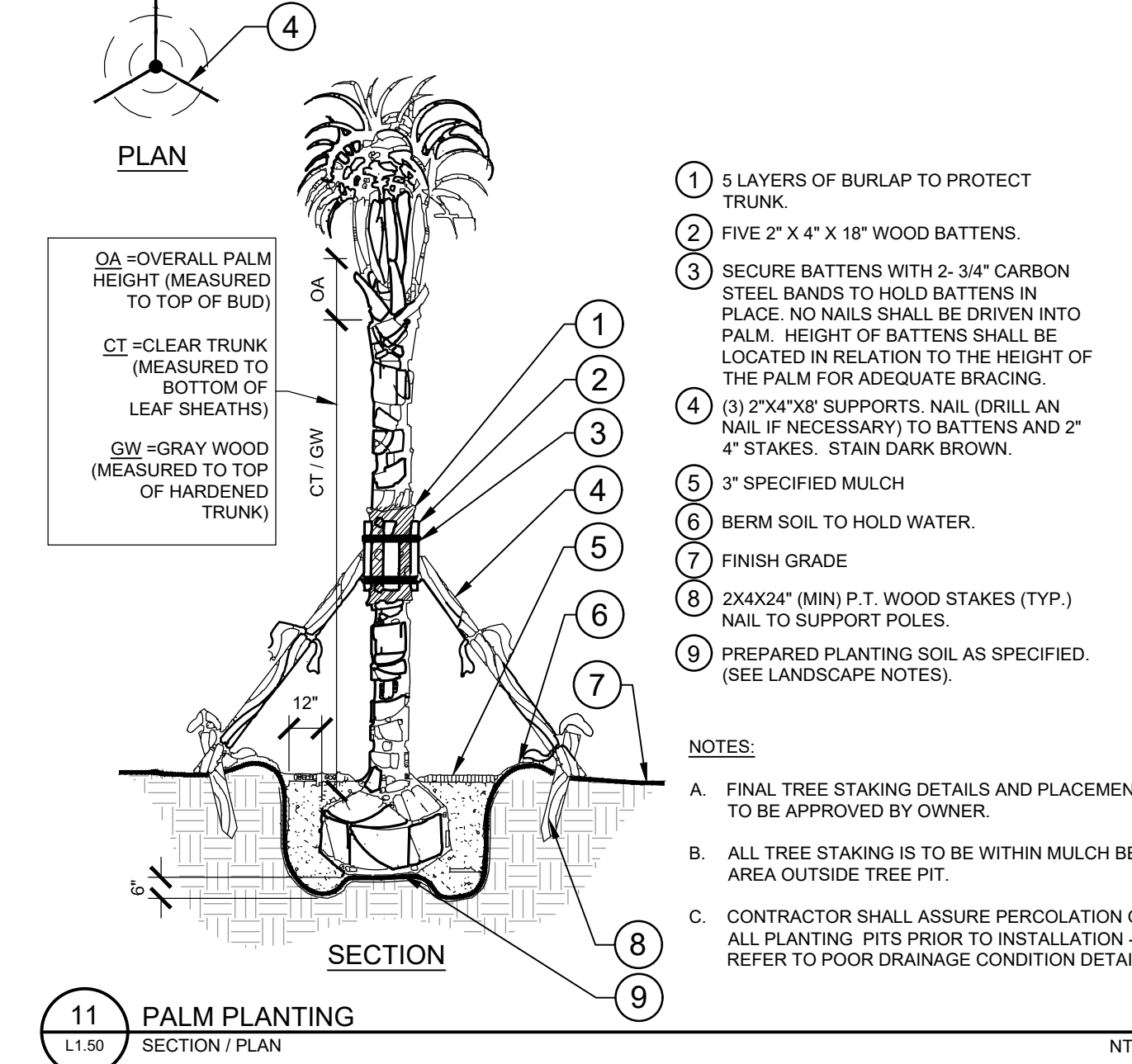
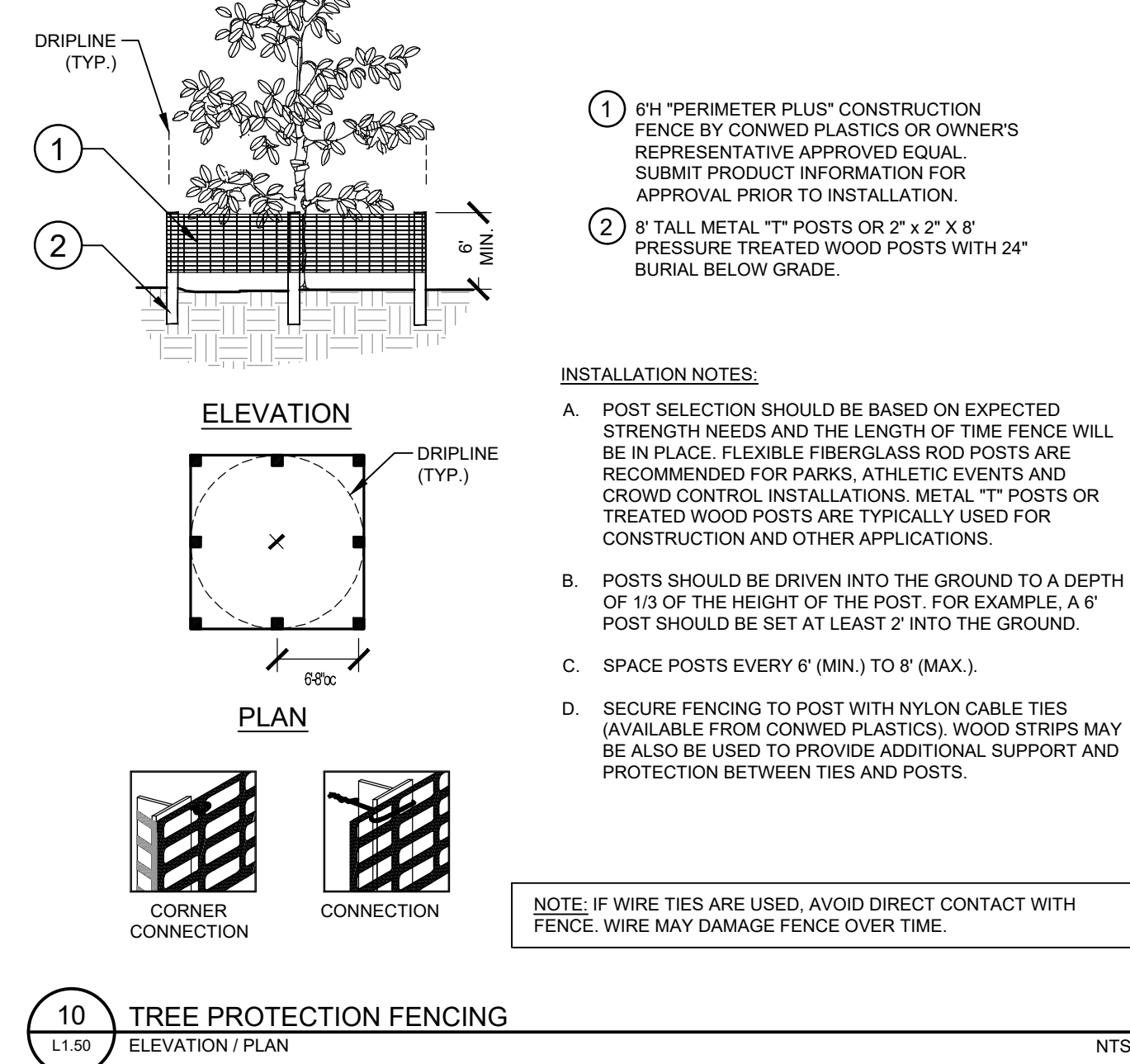
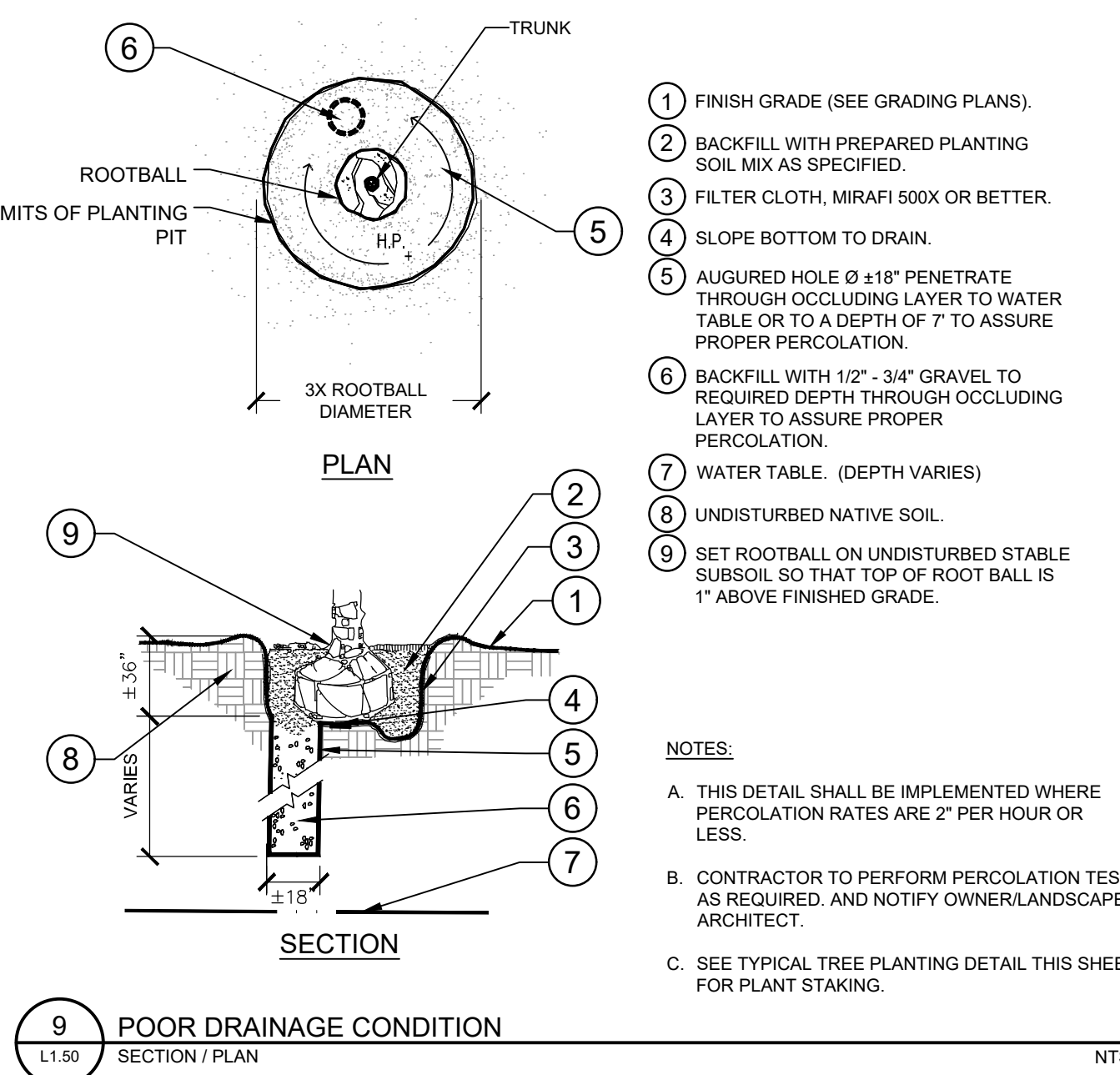
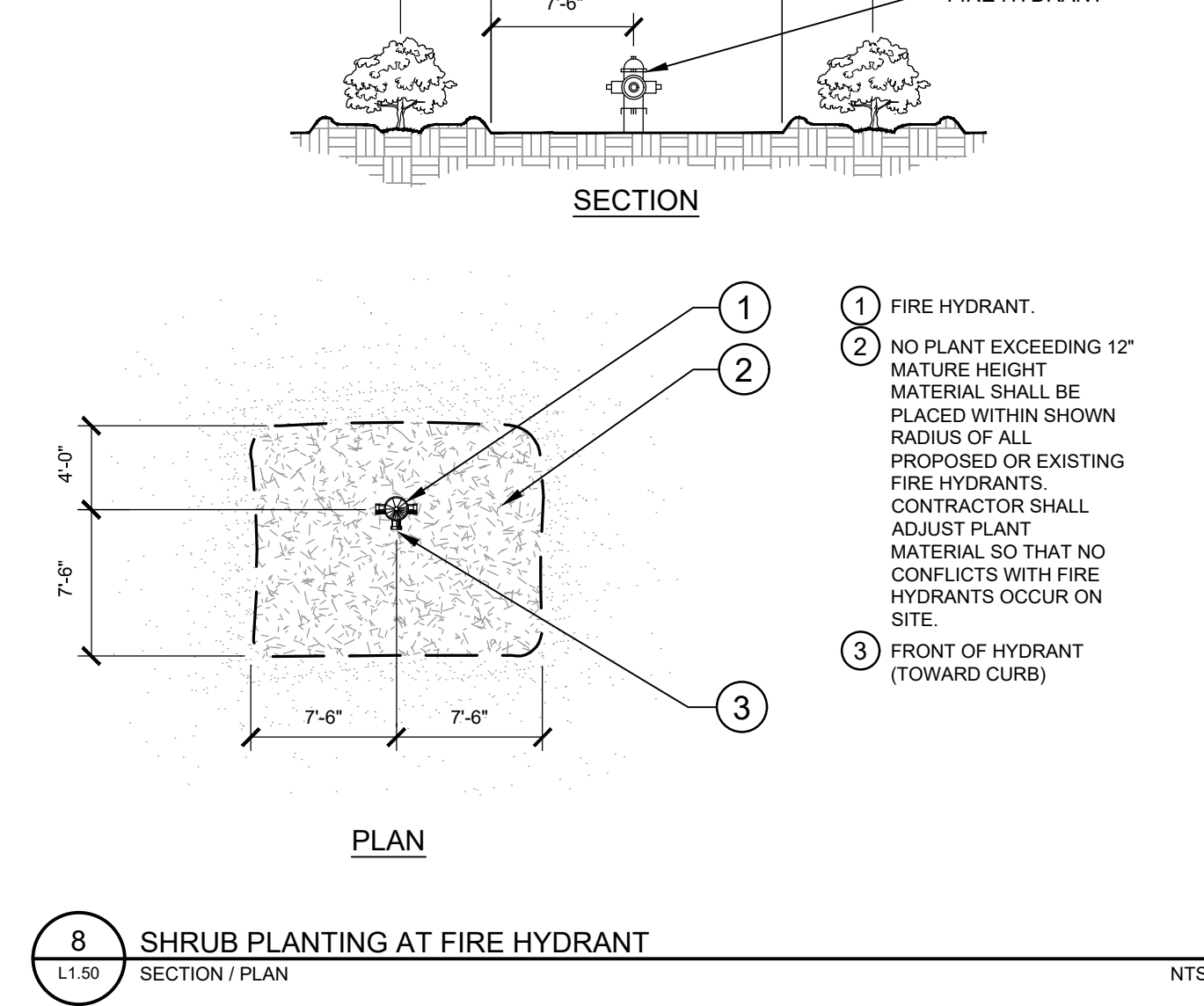
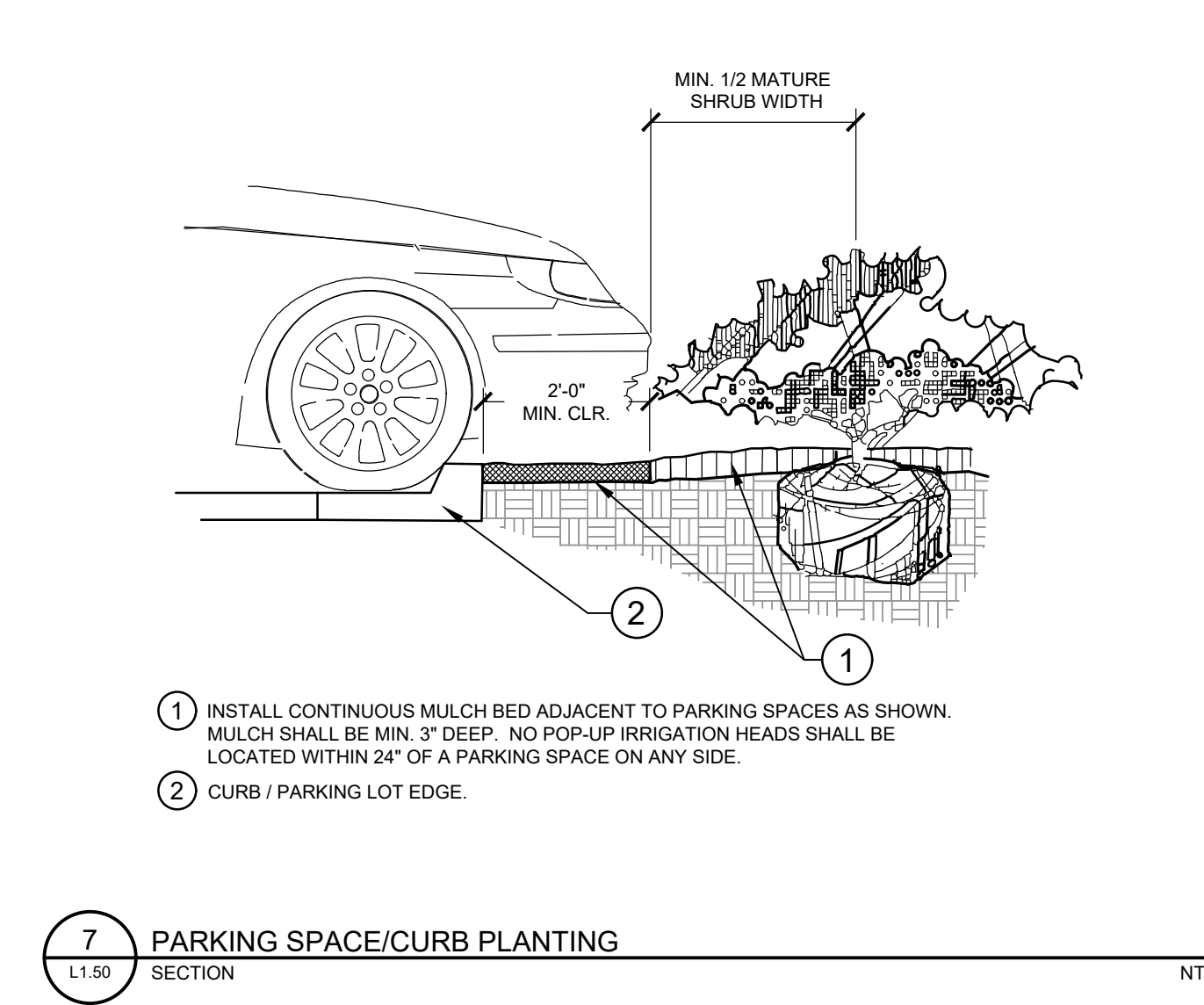
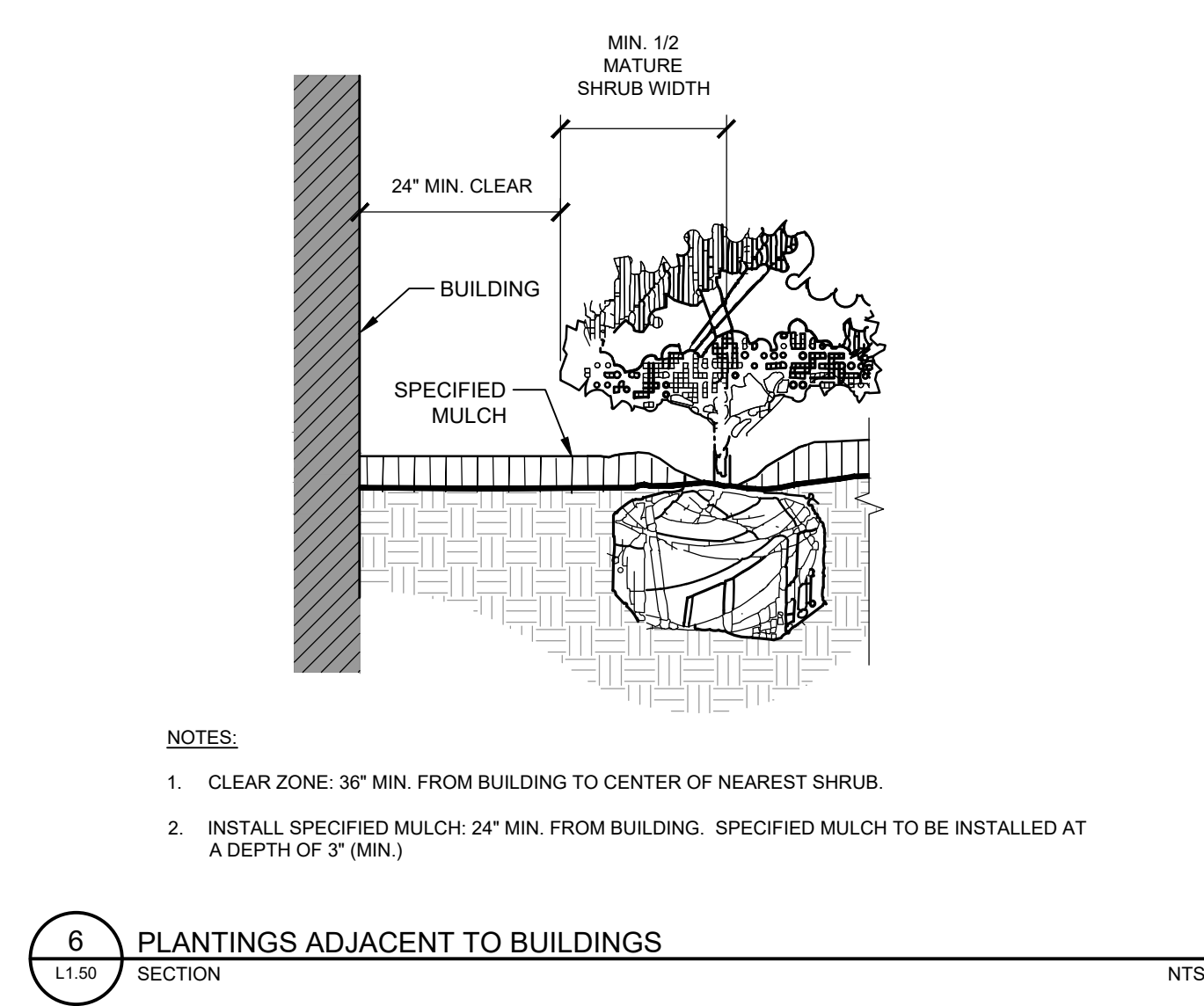
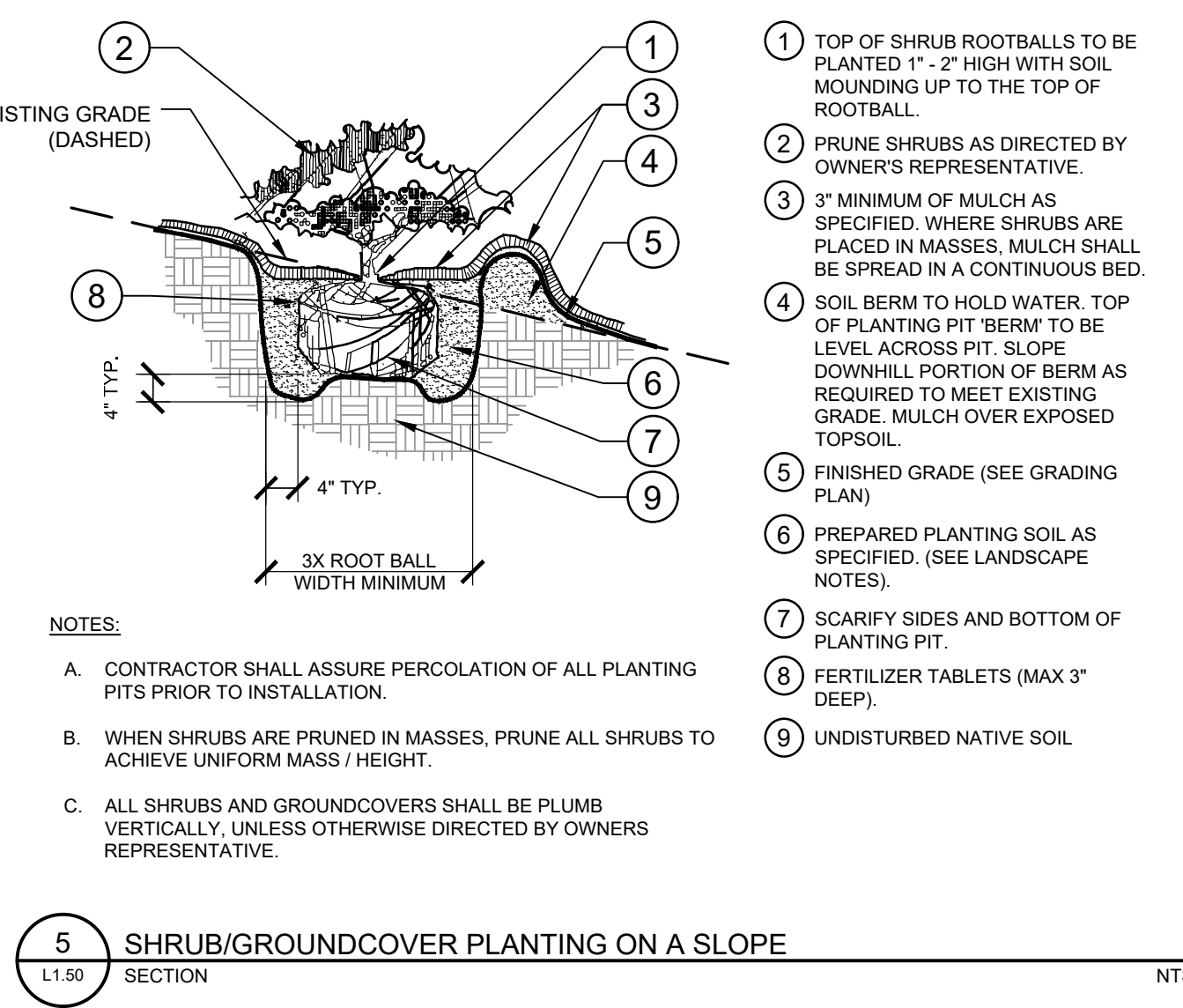
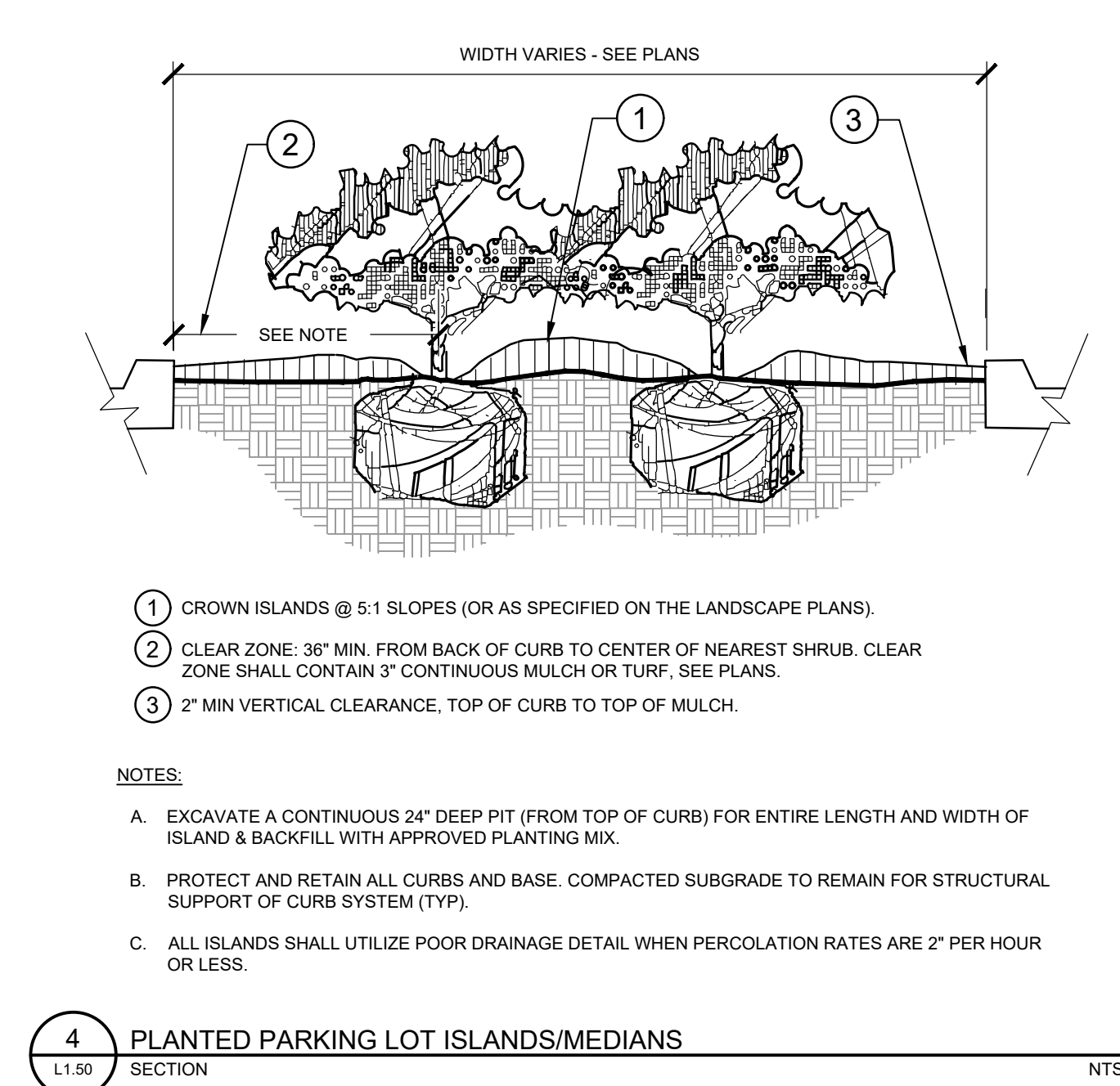
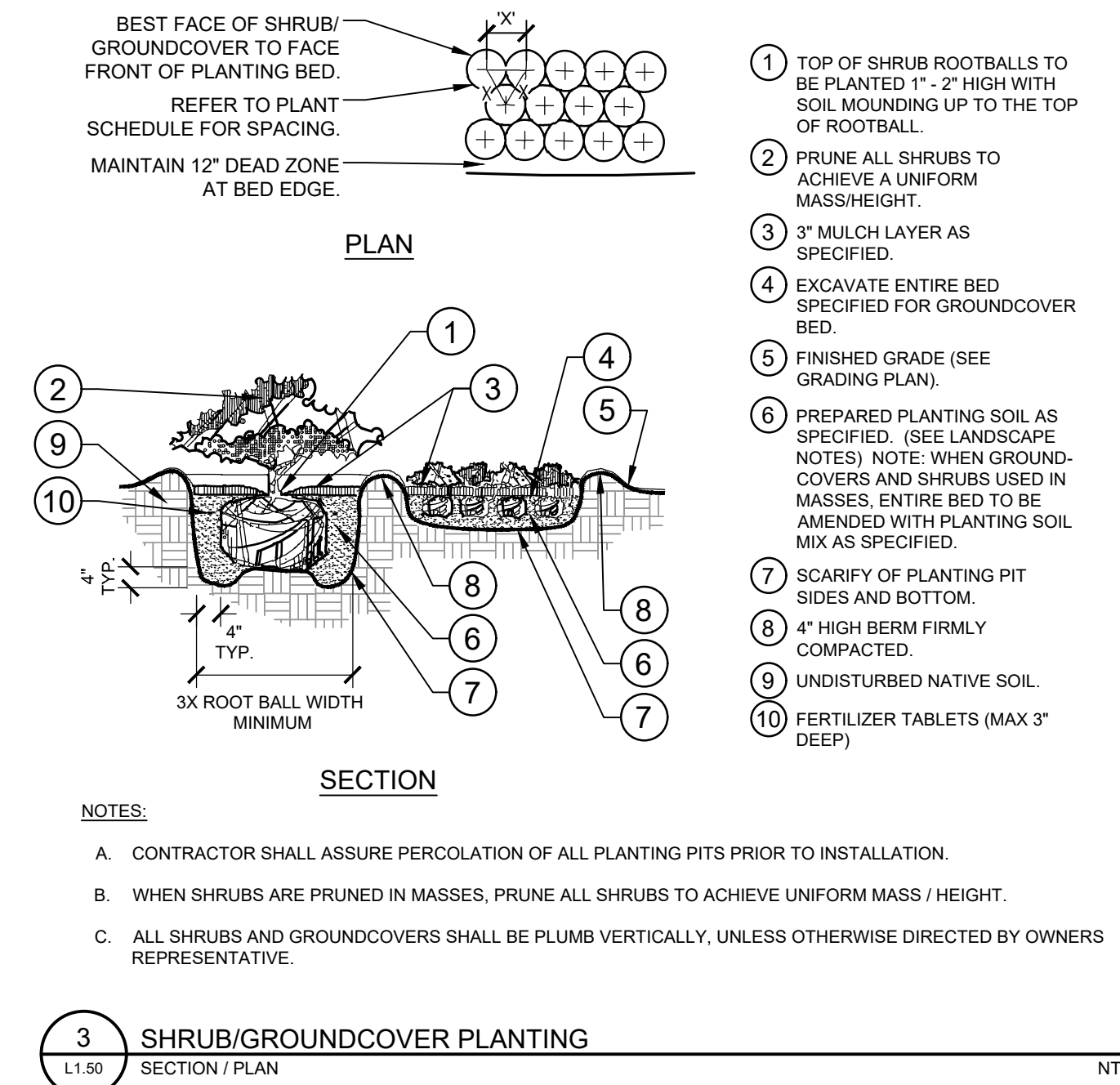
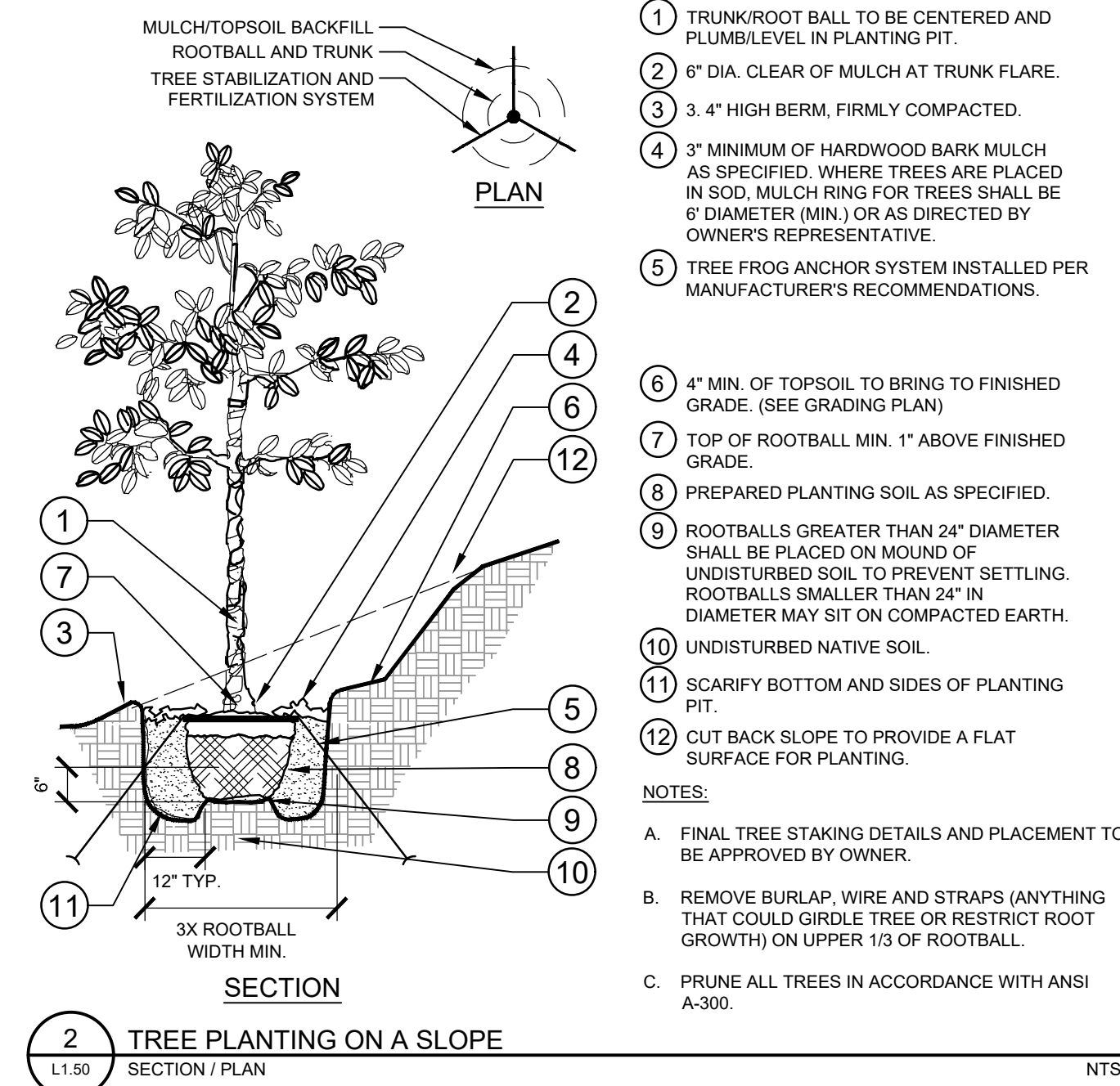
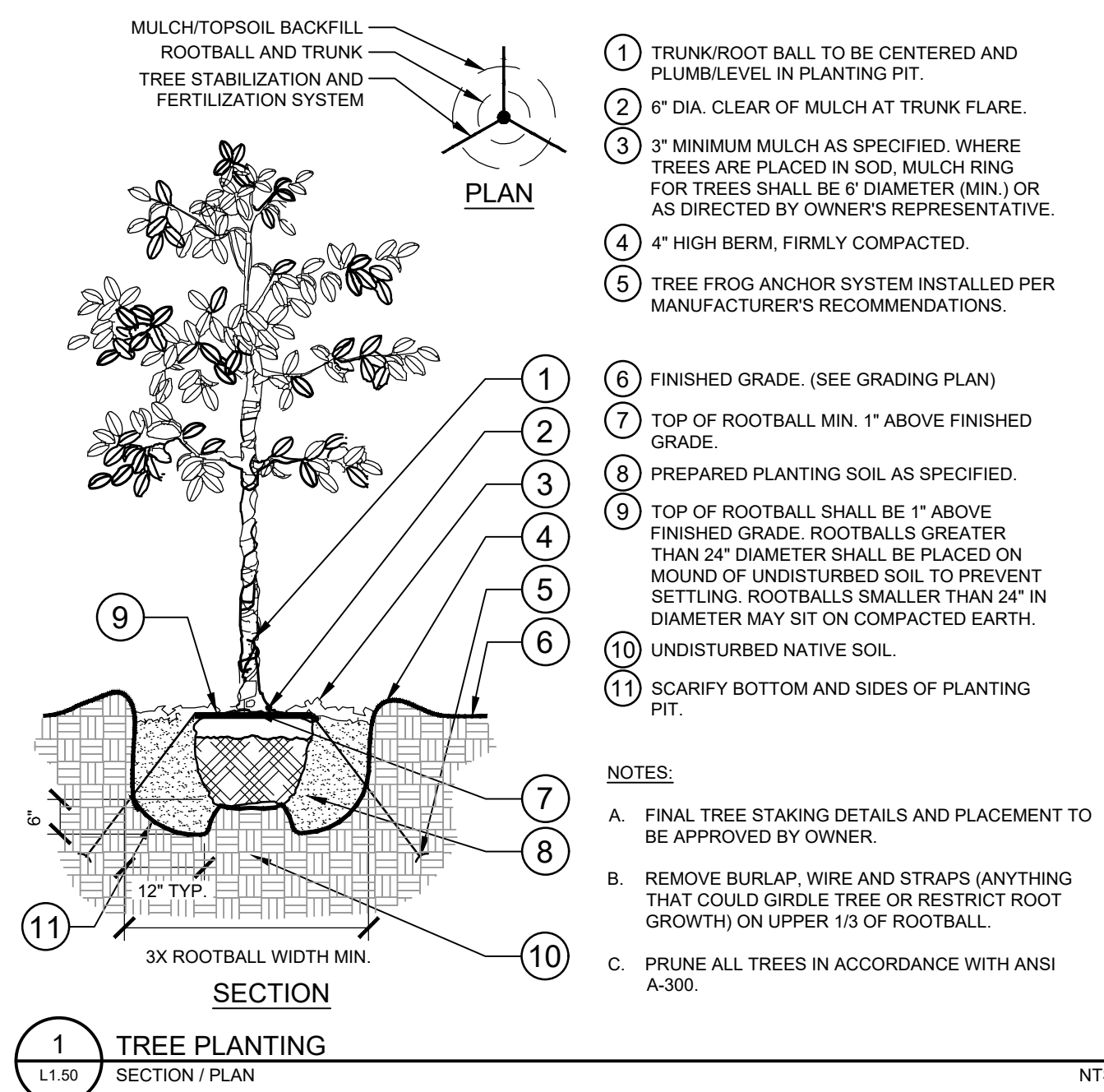

No.	REVISIONS	DATE	BY

Kimley»Horn
 © 2024 KIMLEY-HORN AND ASSOCIATES, INC.
 200 SOUTH ORANGE AVE., SUITE 600, ORLANDO, FL 32801
 PHONE: 407-698-1511
 WWW.KIMLEY-HORN.COM

LICENSED PROFESSIONAL
 KHA PROJECT
 149831018
 DATE
 06/24/2024
 SCALE AS SHOWN
 DESIGNED BY ASIL
 DRAWN BY ASIL
 CHECKED BY JTG
 DATE 6/21/2024

LANDSCAPE DETAILS
MERIDIAN PARKS N6
 PREPARED FOR
 BEACHLINE SOUTH RESIDENTIAL
 CITY OF ORLANDO
 SHEET NUMBER
L1.50